



NICE VOIP RECORDING SOLUTIONS

NICE provides VoIP-based recording solutions that include liability, quality monitoring, and interaction analytics for contact centers and enterprises, as well as for the trading floors and back offices of financial institutions. NICE's patented, scalable VoIP recording solutions are certified by the world's leading VoIP switch vendors, and are suitable for the entire range of customers from the smallest contact center to large, multi-site, multi-branch, high-end environments.

Insight from Interactions™

NICE

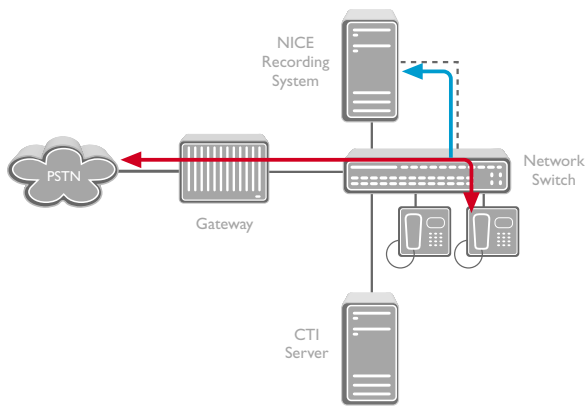

- Recorded call route
- VoIP traffic mirroring of IP phones or gateway

With passive VoIP recording the recording system connects to mirroring (SPAN) ports that reflect the traffic to be recorded

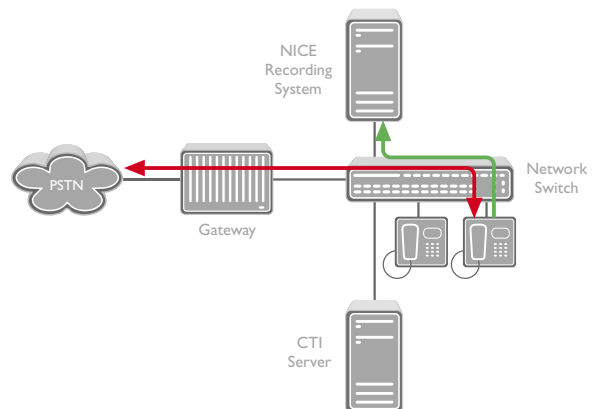

- Recorded call route
- VoIP traffic replica sent over standard network connection

Active VoIP recording can be implemented by the phone sending replicas of the VoIP traffic to the recording system

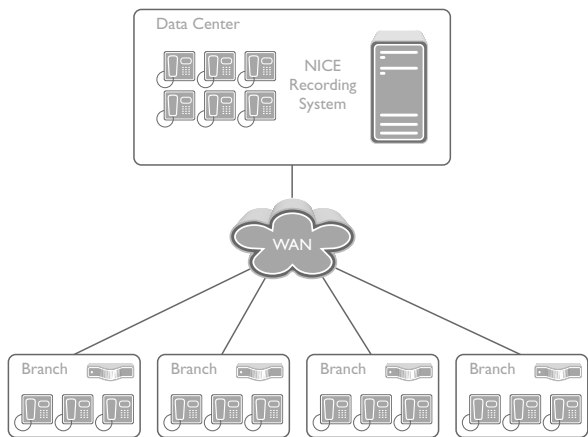

VoIP Recording Gateway

The VoIP Recording Gateway allows centralized recording in a multi-branch environment

NICE Systems (NASDAQ: NICE) is the leading provider of Insight from Interactions™, based on advanced content analytics - of traditional and IP telephony, web, radio and video communications. NICE's solutions improve business and operational performance, as well as security. NICE has over 23,000 customers in 100 countries, including the world's top 10 banks and over 75 of the Fortune 100 companies. More information is available at www.nice.com.

**Global
International HQ**
NICE Systems Ltd
8 Hapnina Street
POB 690
Ra'anana 43107
Israel
T +972 9 775 3777
F +972 9 743 4282

**Americas
North America**
NICE Systems Inc
301 Rt 17 North Floor
Rutherford NJ
07070
USA
T +1 201 964 2600
F +1 201 964 2610

360o View, alpha technologies, Customer Feedback, Dispatcher Assessment, Encoder, eNiceLink, Executive Connect, Executive Insight*, FAST alpha blue, FAST alpha silver, Freedom, Freedom Connect, Interaction Capture Unit, Insight, Insight from Interactions, Investigator, Last Message Replay, Mirra, My Universe, NICE, NICE Analyzer, NiceCall, NiceCall Focus, NiceCLS, NICE Inform, NICE Learning, NiceLog, NICE Perform, NICE Playback Organizer, NiceScreen, NICE Storage Center, NiceTrack, NiceUniverse, NiceUniverse Compact, NiceVision, NiceVision ALTO, NiceVision Harmony, NiceVision Mobile, NiceVision NVSAT, NiceVision PRO, Renaissance, Scenario Replay, ScreenSense, Tienna, Universe, Wordnet and other product names and services mentioned herein are trademarks and registered trademarks of NICE Systems Ltd. All other registered and unregistered trademarks are the property of their respective owners.

**APAC
Asia Pacific**
NICE APAC Ltd
Rooms 1407-08
Harbour Centre
25 Harbour Road
Wanchai, Hong Kong
T +852 2598 3838
F +852 2802 1800

**EMEA
Europe, Middle East & Africa**
NICE CTI Systems UK Ltd
Tollbar Way, Hedge End
Southampton
Hampshire SO30 2ZP
United Kingdom
T +44 8707 224 000
F +44 8707 224 500

ALL CONTENTS OF THIS DOCUMENT ARE COPYRIGHT © 2006 • DATE 03/2006
P/N 406F0246-01

www.nice.com

